

HOPEWIND

LIQUID-COOLING HV-BOX
INTEGRATED STRING PCS

ESHV Series 215kW



FEATURES

- Highly Integrated design with battery rack high voltage box and BCU
- Liquid-cooling, ultra-low noise level (<65dB)
- Small size & high power density
- IP66 protection degree for harsh environment
- Supports multi-module parallel connection
- PQ, VSG operating modes with grid-forming function

TOPOLOGICAL GRAPH

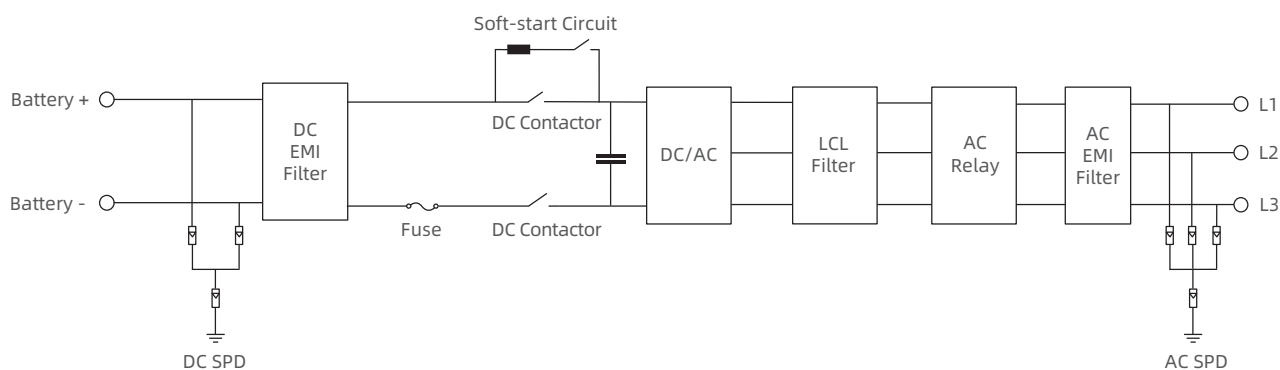

PARAMETERS

Model	ESHV215K-LI-G01
DC Input	
DC Voltage Range	1000~1500V
Max. DC Current	209A
AC Output	
Rated Power	215kW
Max. Output Power	236.5kW (10min @ liquid temperature below 58°C)
Reactive Power Range	0~236.5kvar (10min @ liquid temperature below 58°C)
AC Connection	3W+PE
Isolation	Non-isolated
On-grid	
Rated Grid Voltage	690V
Voltage Range	586~759V
Rated Grid Frequency	50Hz / 60Hz
Frequency Range	45~55Hz / 55~65Hz
THDi	<3% (at rated power)
Power Factor	-1~1
Charge/Discharge Switchover Time	<20ms
Off-grid	
Rated Output Voltage	690V
Voltage Imbalance	<2% (steady-state), ≤4% (transient)
THDu	<3% (no load or rated resistive load)
Overvoltage Protection	Settable
Undervoltage Protection	Settable
General Data	
Grounding System	IT
Operating Ambient Temperature Range	-40~+60°C
Allowable Relative Humidity Range	0~95%
Allowable Altitude Range	<4000m (derating above 3000m)
Anti-corrosion Class	C4 (C5 optional)
Cooling Method	Liquid-cooling
Maximum Coolant Temperature	Max. Coolant Temperature: 58°C Recommended Coolant Temperature: <40°C
Wiring Method	Quick Plug Terminals
Protection Degree	IP66
Indicator	LED Indicator
Communication Interface	Ethernet / RS485 / CAN
Communication Protocol	Modbus TCP / Modbus RTU / CAN 2.0
Dimensions (W*D*H)	745*180*820mm (excludes hanging board) 785*180*820mm (includes hanging board)
Weight	≤80kg (net weight)
Standard Compliance	IEC 62477 and IEC 61000 (In progress) (Please contact Hopewind team for latest certifications)

