

ESHV Series 145~250kW



FEATURES

- Small size & high power density
- Modular design enables accurate management of battery
- IP66 & optional C4~C5 anti-corrosion degree for harsh environment
- Support up to 24 units in parallel connection
- Equipped with grid-forming function
- Variable-speed fans for quiet operation

TOPOLOGICAL GRAPH

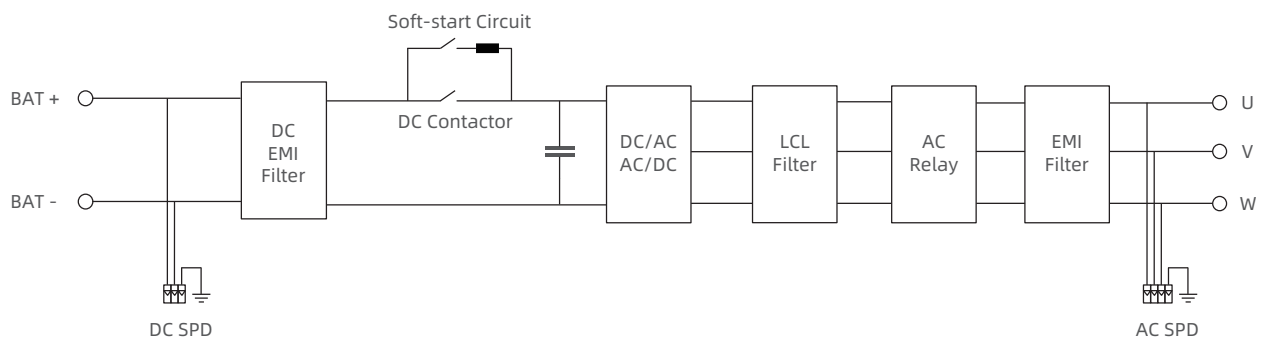

PARAMETERS

Model	ESHV145K-A-G01	ESHV186K-A-G01	ESHV200K-A-G01	ESHV215K-A-G01	ESHV250K-A-G01
DC Input					
DC Voltage Range	580~1500V	1000~1500V			
Max. DC Current	281A	209A	225A	242A	281A
AC Output					
Rated Power	145kW	186kW	200kW	215kW	250kW
Max. Output Power	160kW	205kW	220kW	237kW	275kW
AC Connection	3W+PE				
Isolation	Non-isolated				
Grid-forming Function	Support				
On-grid					
Rated Grid Voltage	400V	690V			
Voltage Range	340~440V	586.5~759V			
Rated Grid Frequency	50Hz / 60Hz				
Frequency Range	45~55Hz / 55~65Hz				
THDi	<3% (at rated power)				
Power Factor	-1~1				
Charge/Discharge Switchover Time	<20ms				
Off-grid					
Rated Output Voltage	400V	690V			
Voltage Imbalance	<2% (steady-state), ≤4% (transient)				
THDu	<3% (no load or rated resistive load)				
Overvoltage Protection	Settable				
Undervoltage Protection	Settable				
General Data					
Grounding System	IT				
Operating Ambient Temperature Range	-40~+60°C (derating above 45°C)				
Allowable Relative Humidity Range	0~95%				
Allowable Altitude Range	<4000m (derating above 3000m)				
DI Port	4				
DO Port	2				
Anti-corrosion Class	C4 (C5 optional)				
Surge Protection	DC Type II / AC Type II				
Wiring Method	Bottom in and bottom out (via quick plug terminals)				
Protection Degree	IP66				
Cooling Method	Smart Air-cooling				
Indicator	LED Indicator				
Communication Interface	Ethernet / RS485 / CAN / Local debugging WiFi (optional)				
Communication Protocol	Modbus TCP / Modbus RTU / CAN 2.0				
Dimensions (W*D*H)	795*294*915mm (excludes hanging board)				
Weight	≤100kg (net weight)				
Standard Compliance	IEC 62477-1	ESHV250K-A-G01: EN 50549-1/-2/-10, GB/T 34120-2023, IEC 62477-1, IEC 61000, IEC60068-2, G99, VDE 4110/4120, NTS V2.1, NTSV1.1 CEI 0-16, IEC TS 62910, etc. ESHV186K~215K-A-G01: IEC 62477-1, IEC 61000, IEC62920, NTS V2.1. NTS V1.1 (Please contact Hopewind team for latest certifications)			