

# HOPEWIND

## GREEN C&I SOLUTION

### PV Grid-tied Inverter

# HSNV25-50K -G01



## FEATURES



### Efficient

- Multi-MPPT with Max. efficiency of 98.60%
- 110% AC overloading
- Up to 20A of MPPT current input to support 210mm & bifacial PV modules



### User Friendly

- Built-in zero export function interface
- Supports country grid code preset
- Remote firmware upgrade
- Near-end commissioning via APP



### Reliable

- Highly precise & intelligent string detection
- Built-in SPD for surge protection & AFCI function
- Wide AC voltage range for unstable grid

## TOPOLOGICAL GRAPH

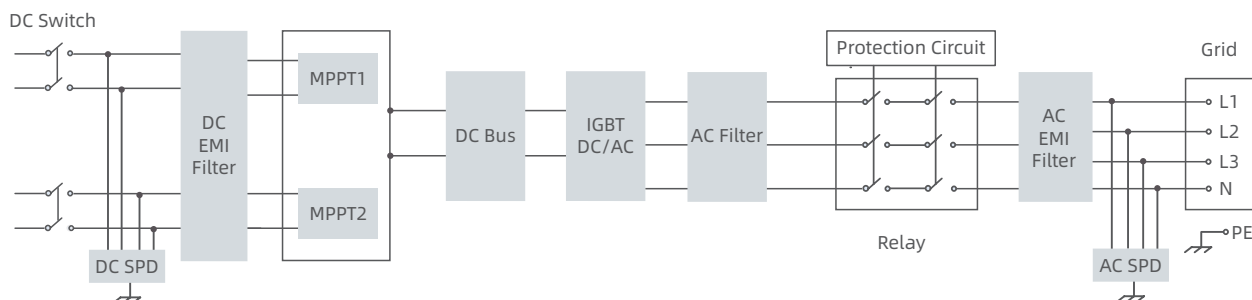

# PARAMETERS

Model	HSNV25K-G01	HSNV30K-G01	HSNV36K-G01	HSNV40K-G01	HSNV50K-G01
<b>DC Input</b>					
Max. Input Voltage	1100 V				
Starting Voltage	200 V				
MPPT Voltage Range	200~1000 V				
Max. Input Current Per MPPT	40 A / 40 A		45 A / 45 A	54 A / 54 A	60 A / 60 A
Max. Short-circuit Current	65 A / 65 A		67.5 A / 67.5 A	81 A / 81 A	90 A / 90 A
Number of DC Inputs	2 / 2	3 / 3		5 / 4	
Number of MPP Trackers	2				
<b>AC Output</b>					
Rated Output Power	25 kW	30 kW	36 kW	40 kW	50 kW
Max. Output Power	27.5 kW	33 kW	39.6 kW	44 kW	55 kW
Rated Output Voltage	230 V / 400 V (3W + N + PE)				
Operating Voltage Range	300~520 V				
Rated Output Current	36.1 A	43.5 A	52.0 A	57.7 A	72.2 A
Max. Output Current	39.7 A	47.8 A	57.2 A	63.5 A	79.4 A
Rated Grid Frequency	60 Hz		50 Hz / 60 Hz		
Power Factor	>0.99 (0.8 leading~0.8 lagging)				
Harmonic (THDi)	<3% (at rated power)				
<b>Efficiency</b>					
Max. Efficiency	98.60%				
European Efficiency	98.30%				
<b>Protection</b>					
Surge Protection	DC type II / AC type II				
PV Reverse Polarity Protection	Yes				
Insulation Impedance Detection	Yes				
Residual Leakage Current Detection	Yes				
Output Overcurrent Protection	Yes				
Anti-islanding Protection	Yes				
Zero Export Function	Yes				
PV String Connection Detection	Yes				
Arc Fault Circuit Interrupter (AFCI)	Yes				
DC Switch	Yes				
<b>General Parameters</b>					
Dimensions (W × H × D)	560 × 823 × 307 mm				
Weight	≤55 kg				
Ingress Protection	IP65				
Operating Temperature	-40~+60°C				
Cooling System	Smart air cooling				
Topology	Transformerless				
Operating Altitude	4000 m (>3000 m derating)				
Display	LED, WLAN + APP				
Communication	RS485 / Wi-Fi				
DC Connection Type	DC connector (4~6 mm <sup>2</sup> )				
AC Connection Type	OT / DT terminal				
<b>Standard Compliance (More Available Upon Request)</b>					
Certification	IEC 62109, IEC 61000, IEC 61727, IEC 62116, IEC 60068, IEC 61683, EN 50549-1, EN 50549-2, VDE 4105, VDE 4110, VDE 4120				

Note: HSNV25/30K-G01 inverter is only applicable to the Brazilian market.

