

HOPEWIND



HV350 Series General Purpose Inverter Selection Manual (0.75kW~560kW)

Corporate Profile

Shenzhen Hopewind Electric Co., Ltd. (Stock Code: 603063) focuses on the R&D, manufacturing, sales and services of renewable energy & electric drive products, including products for wind power generation, photovoltaic generation, energy storage, hydrogen production power supply, power quality and electric drive. Furthermore, Hopewind owns integrated independent R&D and testing platforms of high-power power electrical equipment and monitoring systems. Through innovation in technology and service, Hopewind continuously creates value for customers, and has become one of China's most competitive enterprises in the renewable energy field.

In the field of industrial drive, Hopewind provides a wide range of inverters with various voltage and power classes, mainly including HV350 series low-voltage general purpose inverter, HV510 series low-voltage high-performance inverter, HV610 series crane inverter, HV500 series low-voltage engineering single transmission inverter, HD2000 series low-voltage engineering inverter, HD8000 series medium-voltage engineering inverter, etc., and also provides solutions for 0.75kW~22400kW low-voltage inverter and 4MVA~102MVA (single inverter) medium-voltage inverter. These products can be widely used in metallurgy, petroleum and petrochemical, mining machinery, port lifting, distributed energy generation, large-scale testing platforms, marine equipment, textiles, chemicals, cement, municipal and various other industrial applications.

【Honors】



National Science and Technology Progress Award



Laboratory Qualification Approved by CNAS



National High-tech Enterprise

【Quality System】



Quality Management System



Environmental Management System



Occupational Health and Safety Management System

Headquarter-Shenzhen

5 major R&D and manufacturing bases: Shenzhen, Suzhou, Xi'an, Heyuan, Wuhan

30 service bases: Deployed worldwide and providing comprehensive services for global customers



HV350 Series General Purpose Inverter

Product Overview

The HV350 Series inverter is a newly developed general-purpose vector inverter by Hopewind Electric. It adopts advanced open-loop control technology, supporting asynchronous motor drive control. On the design principles of abundant software functions, better performance and higher reliability, this inverter features smaller volume with improved expandability, more communication functions and easier operation.



Typical Applications

HV350 Series inverters are widely used in textile, papermaking, object hoisting, plastics, metal products, printing and packaging, building materials, engineering machines and automatic production equipment.



papermaking



hoisting



chemical industry



textile



packaging

Naming Rules

HV350 - 4 T 0.75G/1.5P B

Inverter Series Name:
HV350: hopeVert Series General-purpose Inverter

Voltage Level:
4: 380V

Number of Phases:
T: Three-phase

Power Rating:
0.75G: 0.75kW (Heavy Load)
1.5P: 1.5kW (Light Load)

Braking Unit Information:
B: Built-in Braking Unit
Empty: No Built-in Braking Unit

High Reliability

◎ Innovative Independent Air Duct

- The innovative design separates the sensitive devices from the air duct, greatly improving the inverter's adaptability to different environments
- The air duct can protect the inverter from dusts and sundries to avoid electrical short circuit, component damage, etc



◎ Advanced Thermal Design Concept and Professional Thermal Simulation Analysis

- Applying efficient and precise thermal simulation software to ensure the thermal reliability of the inverter
- Adopting advanced thermal testing, validation technology and equipment to verify the theoretical results of the thermal design

◎ Rigorous Temperature Rise Testing

- Rigorous full-load and overload testing procedure and strict acceptance criteria for temperature rise of key components supporting long-time reliable operation of the inverter under extreme load condition
- All products passing high-temperature load aging test before ex-work to ensure that all components of the product can work normally

◎ Three-proof Paint Automatic Spraying Process

- Different spraying strategies can be adopted according to the circuit boards, effectively ensuring the uniformity of the circuit board spraying and the consistency of the same batch of the product

High Adaptability

◎ Wide Voltage Range

- Rated voltage: Three-phase 380V ~ 480V
- Input power frequency: (50Hz/60Hz) ±5%
- Allowable voltage fluctuation range: -15%Vac ~ +10%Vac

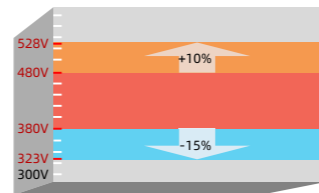

◎ Low External Interference

- Built-in C3 filter can effectively suppress the high-frequency harmonics generated during the operation of the inverter, meeting the requirements of the EU EN61800-3 standard.
- Simple and user-friendly EMC grounding design effectively reduces ground leakage current.

◎ System Certification

- European Union CE certification

◎ Structural Design

- Book-shaped design with the volume 40% less than traditional models
- Supporting side-by-side installation of multiple inverters

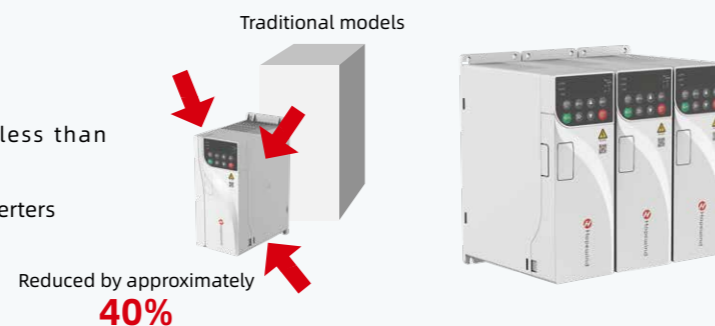

Outstanding Performance

◎ Comprehensive Motor Drive Technology

- Supporting the drive control of three-phase asynchronous motors
- Supporting V/F control, open-loop vector control
- Supporting speed and torque control
- Supporting speed tracking with less impact current

◎ Accurate Motor Auto-tuning Function

- Supporting accurate auto tuning on motor parameters for convenient operation and debugging, higher control precision and faster response speed
- Comprehensive motor auto-tuning functions, including dynamic, static and static+dynamic auto-tuning

Motor Auto-tuning	
Dynamic Auto-tuning	Applicable to load-disconnected scenarios requiring high control precision
Static Auto-tuning	Applicable to load-connected scenarios where dynamic auto-tuning is not recommended

◎ Comprehensive Motor Control Modes

- V/F Control Mode
- Open-loop Vector Control Mode(OLVC)

◎ Large Starting Torque

- Open-loop vector control (OLVC): 150% at 0.5Hz

◎ High Overload Capacity

- Light overload capacity: 110% of I_L for 60s or 150% of I_L for 10s in a duty cycle
- Heavy overload capacity: 150% of I_H for 60s or 180% of I_H for 10s in a duty cycle

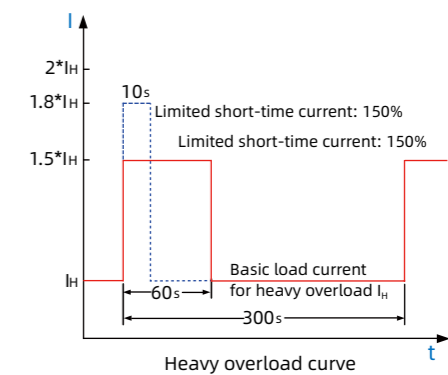
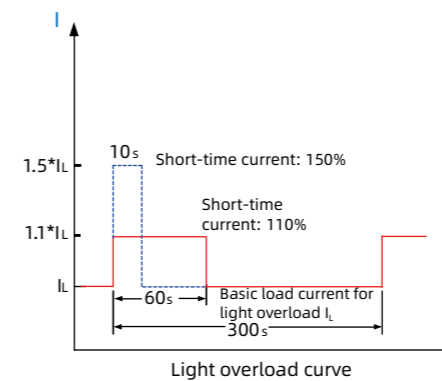

Diversified Functions

Keypad

- 110 kW or below inverters are configured with a built-in LED keypad as standard, which cannot be removed and used externally. If external use is needed, an optional LED keypad can be configured. The keypad can be installed on the cabinet when combined with the mounting base.
- 132 kW or above inverters are configured with a removable LED keypad (mounting base excluded) as standard. To install it on the cabinet, a mounting base should be selected.
- Both standard and optional keypads support parameter debugging, operation state monitoring, start/stop control, parameter copying, etc.

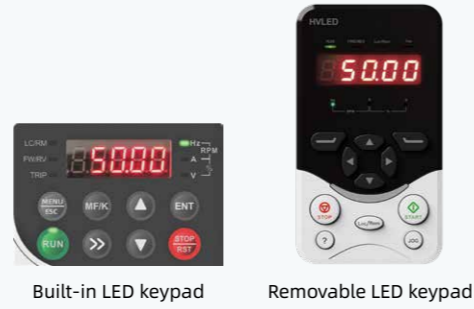

Various Expansion Functions

- Optional expansion communication cards support Profibus-DP, Profinet IO, CANopen, Modbus TCP/IP, Ethercat, EtherNet/IP, and other bus communications (SLOT1 expansion card slot)
- Optional I/O terminal expansion cards (SLOT1 expansion card slot, please refer to "Optional Accessories" for details)



Note: As the optional I/O terminal expansion card and communication expansion card share the same card slot, they cannot be installed and used at the same time.

Abundant I/O Interfaces

Terminal types	Quantity	Features
Digital input	5	Input impedance: 2kΩ, supporting both sourcing and sinking inputs DI5 supports high-speed pulse input with a maximum input frequency of 100kHz.
Analog input	2	0 ~ 10V, 0 ~ 20mA.
Digital output	2	Open collector output; Output voltage range: 0V~24V; Current load capacity: 50mA DO1 supports high-speed pulse output with a maximum output frequency of 100kHz.
Analog output	1	0 ~ 10V, 0 ~ 20mA.
Relay output	1	3A, 250VAC, 30VDC; NO+NC
Power output	2	+10V±2%; +24V±10%.
Communication interface	1	RS485, Modbus RTU protocol

Note: Optional I/O terminal expansion cards are supported which provide 3 DI input channels, 1 DO output channel, 1 AI input channel (-10 V to 10 V), 2 AO output channels (0-10 V/0-20 mA), 1 temperature sampling channel (PT100, PT1000, KTY84), and 1 relay output channel.

Reliable Braking Function

- The inverter supports DC braking.
- Models of 22kw and below are equipped with a standard built-in braking unit while models of 30kw to 560kw with an optional one.
- Adding a braking resistor enhances braking performance while saving electrical installation space and reducing user electrical costs.

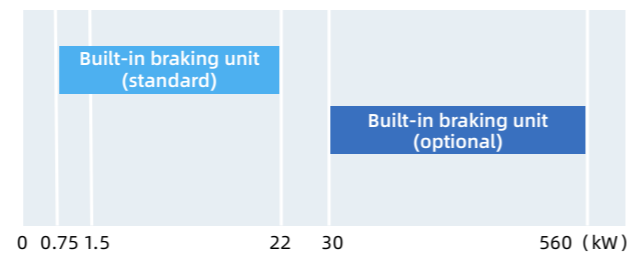

Supporting Various Functions

- Supporting V/F Supporting V/F half separation and complete separation modes
- Supporting process PID control which can be applied in constant temperature control, constant pressure control and tension control
- Supporting wobble function which can be applied in fiber and textile industries
- Supporting random PWM depth to reduce motor noise

Supporting Background Software for Quick Debugging

- Supporting such functions as monitoring and parameter editing
- Supporting event logs and fault record

Parameter interface

Fault record

Event logs

序号	类别	日期	时间	来源	事件代码	事件名称	事件状态	DSP索引
1	A_Alarm	2017-11-16	09:55:56	整流单元1	1177	电网电压欠压	清除	211
2	S_Event	2017-11-16	09:55:56	整流单元1	2220	整流状态切换至零速运行态	清除	210
3	A_Alarm	2017-11-16	09:55:56	整流单元1	1177	电网电压欠压	清除	209
4	S_Event	2017-11-16	09:54:58	整流单元1	2402	速度反馈异常	清除	208
5	S_Event	2017-11-16	09:54:42	整流单元1	2401	速度反馈异常	清除	207
6	S_Event	2017-11-16	09:54:42	整流单元1	2402	速度反馈异常	清除	206
7	S_Event	2017-11-16	09:54:35	整流单元1	2401	速度反馈异常	清除	205
8	S_Event	2017-11-16	09:54:35	整流单元1	2402	速度反馈异常	清除	204
9	S_Event	2017-11-16	09:54:28	整流单元1	2401	速度反馈异常	清除	203
10	S_Event	2017-11-16	09:54:16	整流单元1	2402	速度反馈异常	清除	202
11	S_Event	2017-11-16	09:54:00	整流单元1	2401	速度反馈异常	清除	201
12	S_Event	2017-11-16	09:53:16	整流单元1	2402	速度反馈异常	清除	200
13	S_Event	2017-11-16	09:53:07	整流单元1	2401	速度反馈异常	清除	199
14	S_Event	2017-11-16	09:52:55	整流单元1	2402	速度反馈异常	清除	198
15	S_Event	2017-11-16	09:52:47	整流单元1	2401	速度反馈异常	清除	197
16	S_Event	2017-11-16	09:52:41	整流单元1	2402	速度反馈异常	清除	196

Technical Data

Projects		Specification Description and Technical Data	
Power input/output	Input voltage	Input voltage: 380V (-15%) to 480V (+10%) Phase: Three-phase	
	Input power frequency	50Hz/60Hz ±5%	
	Input voltage imbalance	≤3%	
	Output voltage	0V~Input voltage	
	Output frequency	0 ~ 600Hz	
Master control performance	Motor type	Asynchronous motor	
	Control mode	V/F, OLVC(Open-loop Vector Control)	
	Speed range	1:100 V/F; 1:200 OLVC	
	Starting torque	OLVC: 150%(0.25Hz)	
	Torque precision	±5% (OLVC, above 5Hz)	
	Torque ripple	≤±5%, in Vector control mode	
	Speed stability	OLVC, 0.2%	
	Torque response	≤5ms, in Vector control mode	
	Acceleration/deceleration time	0.0s~3200.0s; 0.0min~3200.0min	
	Torque boost	0.0%~30.0%	
	Overload capacity	G type: 150% 1min/5min; 180%10s/5min; P type: 110% 1min/5min; 150% 10s/5min	
	V/F curve	Straight-line type, multi-point type, V/F Half separation mode, V/F complete separation mode	
	Input frequency resolution	Digital setting: 0.01Hz, Analog setting: maximum frequency ×0.025%	
	Main functions	Acceleration/deceleration curve	Straight line and S-curve
		Simple PLC, Multi-speed control	16 speed segments supported through control terminals
Automatic voltage regulation (AVR)		Automatically keeps the output voltage constant when grid voltage varies within a certain range	
Fixed length control		Control with given length	
Built-in PID		Easily forms a closed-loop control system	
Multi-motor switching		Switchover between two groups of motor parameters to control the two motors	
Virtual I/O		8 groups of virtual VDI/VDO, 3 groups of AI as DI, enabling simple logic control	
Overvoltage/Overcurrent stall control		Automatic current and voltage limitation during operation preventing the inverter from tripping due to frequent overcurrent or overvoltage	
Restart after power failure		After power failure and restoration, the inverter waits for a set time before automatically running	
Quick current limiting		Avoids frequent overcurrent faults in the inverter	
Power input/output		Frequency setting method	Keypad; terminal UP/DOWN; multi-reference; pulse reference; communication
		Analog input terminals	AI1; AI2: 0V~10V/ 0 (4)mA~20mA
		Digital input terminals	DI1-DI5, 5 programmable digital input terminals with opto-isolation, compatible with both sinking/sourcing inputs. DI5 supports high-speed pulse input with a maximum input frequency of 100kHz.
		Digital output terminals	Open-collector output; output voltage range: 0V~24V; current load capacity: 50mA. DO1 supports high-speed pulse output with a maximum output frequency of 100kHz.
		Analog output terminals	1-channel 0V ~ 10V/0(4)mA ~ 20mA
Communication	Relay output	1-channel Form C contact, NO+NC	
	Communication protocols	Modbus RTU (standard configuration); Profibus-DP; Profinet IO; CANopen; Modbus TCP/IP; Ethercat; EtherNet/IP (optional configuration)	
Ambient requirements	Altitude	≤1000m: no need for derating 1000~3000m: current derating by 1% per 100m increased	
	Ambient temperature	-25°C ~ +40°C (Running with derating allowed between 40~55)	
	Humidity	15% ~ 95%, No condensation	
	Vibration	3M3, IEC60721-3-3	
	Storage temperature	-40°C~+70°C	
Installation place	Indoor, without direct sunlight, free from flammable, corrosive gases, liquids, and conductive particles.		
Optional accessories	Communication expansion card, I/O terminal expansion cards		
Protections	Protection against short circuit, overcurrent, overload, overvoltage, undervoltage, phase loss, overtemperature, external faults, etc.		
Installation method	Installed in a cabinet		
Protection rating	IP20		
Cooling method	Air cooling		

Product Selection

HV350 Product Selection

■ **Rated voltage: three-phase 380Vac (suitable for operating voltage range of 323V~528V)**

Model	Heavy Load		Light Load		Frame Type
	Rated Power (kW)	Rated Output Current	Rated Power (kW)	Rated Output Current (A)	
HV350-4T0.75G/1.5PB	0.75	2.5	1.5	4.2	FA
HV350-4T1.5G/2.2PB	1.5	4.2	2.2	5.8	
HV350-4T2.2G/4PB	2.2	5.8	4	9.5	
HV350-4T4G/5.5PB	4	9.5	5.5	13	FB
HV350-4T5.5G/7.5PB	5.5	13	7.5	17	
HV350-4T7.5G/11PB	7.5	17	11	25	FC
HV350-4T11G/15PB	11	25	15	32	
HV350-4T15G/18PB	15	32	18.5	38	FD
HV350-4T18G/22PB	18.5	38	22	46	
HV350-4T22GB	22	46	/	/	FE
HV350-4T30G/37P(B)	30	60	37	75	
HV350-4T37G/45P(B)	37	75	45	91	FF
HV350-4T45G/55P(B)	45	91	55	125	
HV350-4T55G/75P(B)	55	125	75	150	FG
HV350-4T75G/90P(B)	75	150	90	180	
HV350-4T90G/110P(B)	90	180	110	210	F8
HV350-4T110G/132P(B)	110	210	132	250	
HV350-4T132G/160P(B)	132	256	160	310	F9
HV350-4T160G/200P(B)	160	312	200	380	
HV350-4T200G/220P(B)	200	380	220	415	F10
HV350-4T220G/250P(B)	220	415	250	471	
HV350-4T250G/280P(B)	250	471	280	510	F11
HV350-4T280G/315P(B)	280	510	315	610	
HV350-4T315G/355P(B)	315	610	355	670	
HV350-4T355G/400P(B)	355	670	400	745	
HV350-4T400G/450P(B)	400	745	450	820	
HV350-4T450G/500P(B)	450	820	500	860	
HV350-4T500G/560P(B)	500	860	560	990	
HV350-4T560G/630P(B)	560	990	630	1100	

- Notes: 1. For frames of FA~FD, built-in braking units are configured; for frames of FE and above, braking units can be purchased by adding "B" at the end of the model.
 2. Only 132kW-400kW products are equipped with built-in DC reactors as standard. For other power segment products, DC reactors are not supported and users can install AC input reactors by themselves as needed. 450kW-560kW inverters must be installed with AC reactors.
 3. A periodic overload of 150% of the baseload is allowed under heavy load rated working conditions (140% for the HV350-4T560G/630P) and 110% under light load rated working conditions. The overload cycle is 1 min every 5 min.

Recommended AC Input Reactor Selection

Model	AC Input Reactor		AC Output Reactor	
	Inductance (mH)	Current (A)	Inductance (mH)	Current (A)
HV350-4T0.75G/1.5PB	7	4.4	1.7	4.4
HV350-4T1.5G/2.2PB	3.5	6.4	1.3	6
HV350-4T2.2G/4PB	2.4	11.5	0.8	10
HV350-4T4G/5.5PB	1.4	16	0.6	14
HV350-4T5.5G/7.5PB	1	20	0.43	18
HV350-4T7.5G/11PB	0.8	29	0.3	26
HV350-4T11G/15PB	0.52	40	0.23	34
HV350-4T15G/18PB	0.4	50	0.2	40
HV350-4T18G/22PB	0.31	59	0.16	48
HV350-4T22GB	0.26	81	0.12	63
HV350-4T30G/37P(B)	0.2	99	0.1	78
HV350-4T37G/45P(B)	0.16	120	0.08	95
HV350-4T45G/55P(B)	0.13	148	0.06	130
HV350-4T55G/75P(B)	0.1	200	0.05	155
HV350-4T75G/90P(B)	0.08	220	0.04	190
HV350-4T90G/110P(B)	0.07	270	0.035	220
HV350-4T110G/132P(B)	0.06	330	0.03	265
HV350-4T132G/160P(B)	0.042	335	0.021	325
HV350-4T160G/200P(B)	0.037	375	0.017	400
HV350-4T200G/220P(B)	0.034	415	0.016	435
HV350-4T220G/250P(B)	0.030	470	0.014	495
HV350-4T250G/280P(B)	0.027	525	0.013	535
HV350-4T280G/315P(B)	0.024	590	0.011	640
HV350-4T315G/355P(B)	0.021	665	0.01	705
HV350-4T355G/400P(B)	0.019	745	0.009	785
HV350-4T400G/450P(B)	0.017	840	0.008	860
HV350-4T450G/500P(B)	0.032	840	0.0077	905
HV350-4T500G/560P(B)	0.026	960	0.0067	1040
HV350-4T560G/630P(B)	0.022	1100	0.006	1155

Product Dimensions

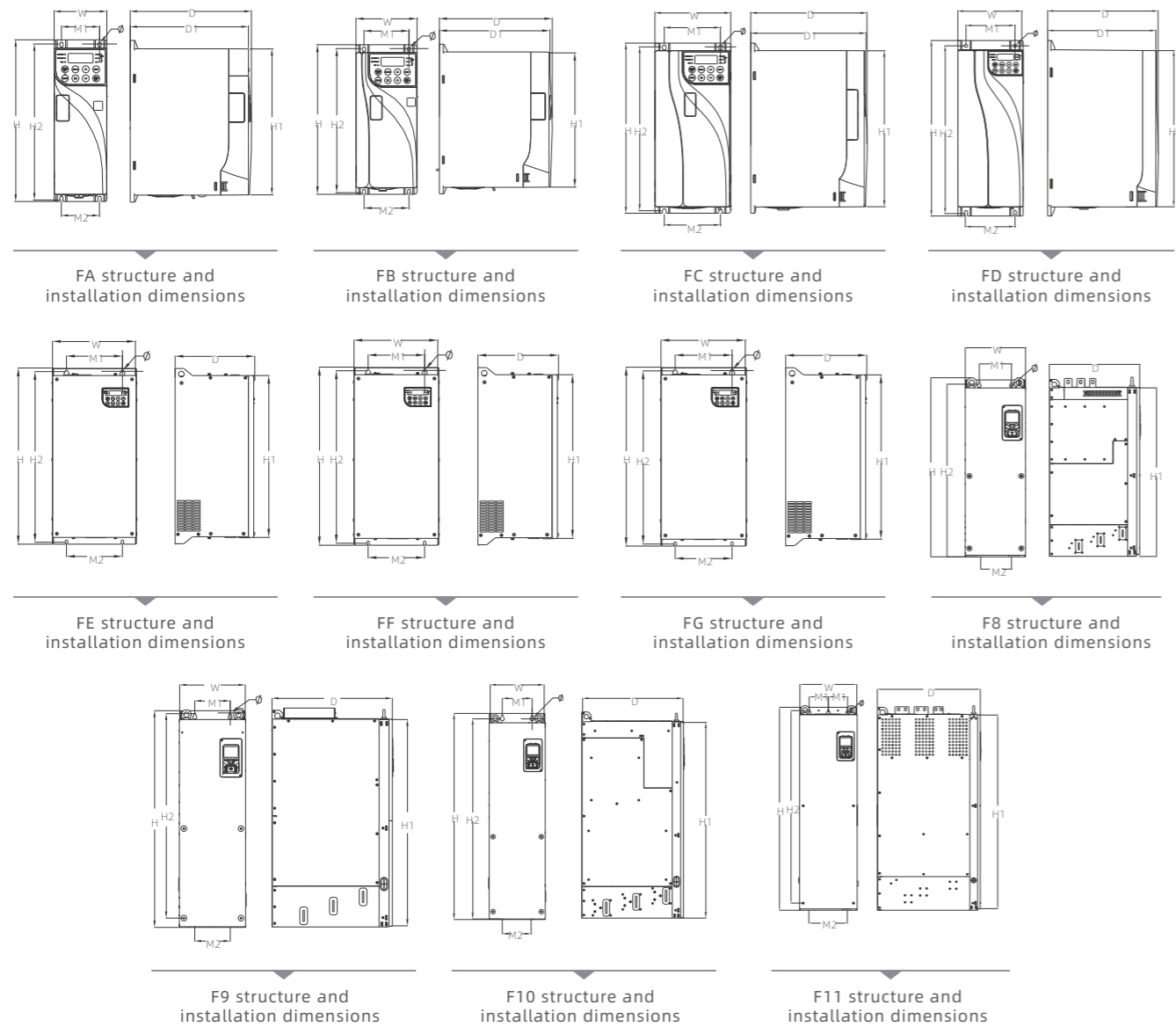

Frame	Width (mm)	Height (mm)	Depth (mm)	Mounting Hole Horizontal Spacing M1 (mm)	Mounting Hole Horizontal Spacing M2 (mm)	Mounting Hole Vertical Spacing H2 (mm)	Mounting Hole Diameter Φ (mm)	Net Weight (kg)
FA	76	232	175.5	55	55	221	5	1.7
FB	95	232	175.5	70	70	221	5	1.8
FC	121.5	272	187	90	90	262	6	3.3
FD	140	377	237	105	105	357	6.5	5.5
FE	240	500	225	160	160	485	7	16
FF	270	615	240	200	200	594	9	24
FG	335	712	255	230	230	688	9	38
F8	300	880	450	160	160	825	9	105
F9	300	980	545	160	160	925	9	122
F10	300	1100	545	160	160	1050	9	156
F11	330	1220	590	110	220	1150	9	209

Note: If there are any changes in product dimensions and parameters, the latest physical product shall prevail.

Standard Wiring Diagram

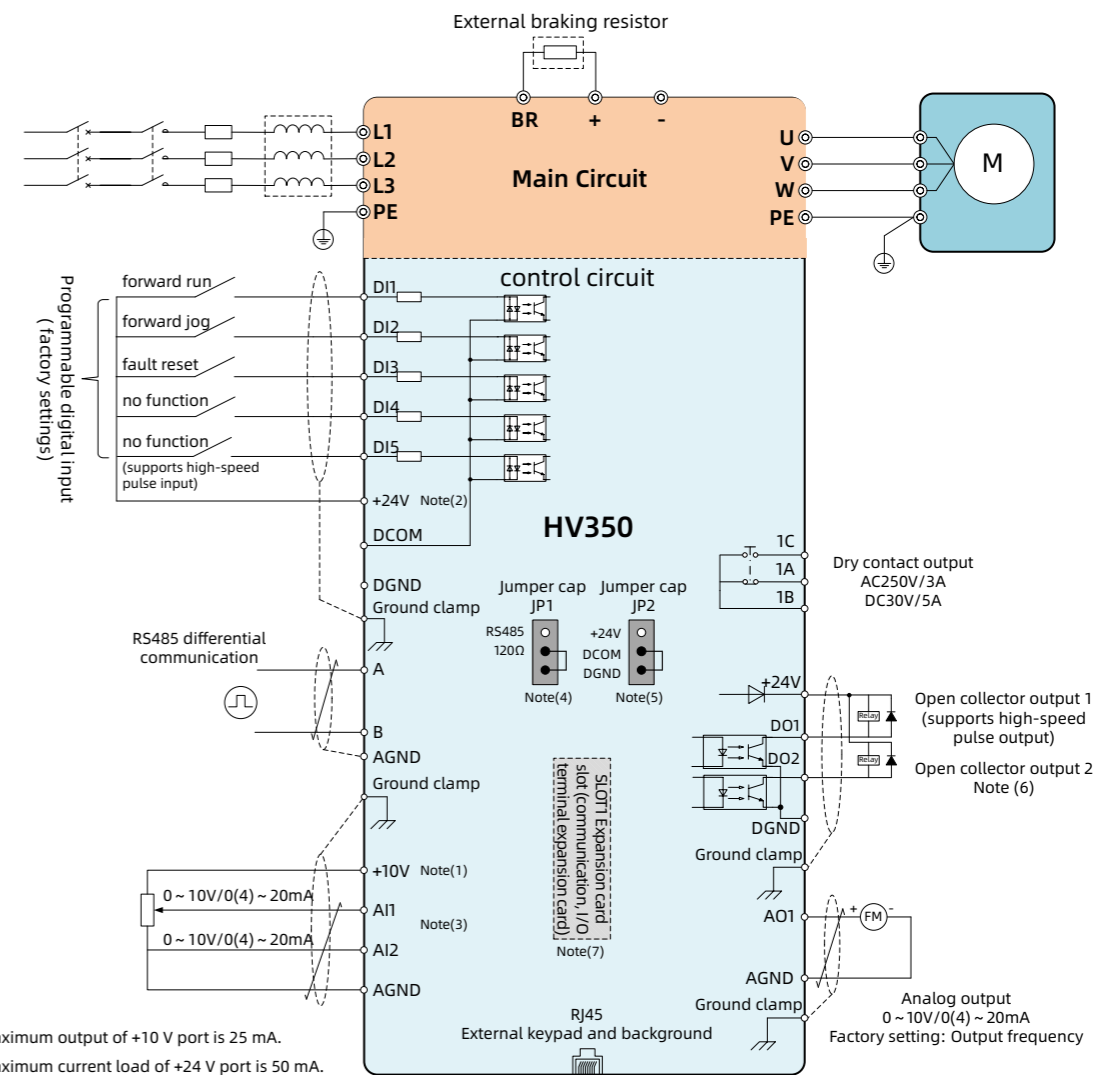

- Note (1): The maximum output of +10 V port is 25 mA.
- Note (2): The maximum current load of +24 V port is 50 mA.
- Note (3): Internal resistance of AI1 and AI2 ports (in current mode): 500 Ω
- Note (4): The activation ports for RS485 terminal resistance (120 Ω).
- Note (5): For terminals DI1-DI5, NPN or PNP transistor signals can be selected as inputs, and the bias voltage can be selected from the inverter's internal power supply (+24 V terminal) or external power supply (DGND terminal).
- Note (6): When the digital output terminals drive the relay, a freewheel diode needs to be added with correct polarity at both ends of the relay coil, otherwise, the internal circuit may be damaged. The driving capacity is not more than 50 mA.
- Note (7): The optional I/O terminal expansion card and the communication expansion card share the same expansion card slot, and cannot be installed and used at the same time.

Optional Accessories

Model	Accessory Name	Function and Use
HVLED	LED keypad	Supports parameters setting, viewing, copying, etc. (Keypad mounting base included)
HVKMB	Keypad mounting base	Supports inverter control by the keypad after installing the base in the specified position
HVCOM-USB	Communication adapter	Enables high-speed communication between hopeinsight (the background quick debugging software of the inverter) and a computer
HVIO-01	I/O terminal expansion card	Supports 3 DI input channels, 1 DO output channel, 1 AI input channel (-10 V~10 V), 2 AO output channels (0~10 V/0~20 mA), 1 temperature sampling channel (PT100, PT1000, KTY84), and 1 relay output channel
HVCOM-DP-H	Profibus-DP communication card	Side insert communication card supporting Profibus-DP bus communication. All frames support side insert communication cards.
HVCOM-DP-V	Profibus-DP communication card	Direct insert communication card supporting Profibus-DP bus communication. Only FA, FB and FC frames support direct insert communication cards. When the three frames are seamlessly installed side by side, the HVCOM-DP-V communication card should be used
HVCOM-PN-H	Profinet communication card	Supports CANopen bus communication
HVCOM-PN-V	Profinet communication card	Direct insert communication card supporting Profinet IO bus communication. Only FA, FB and FC frames support direct insert communication cards. When the three frames are seamlessly installed side by side, the HVCOM-PN-V communication card should be used
HVCOM-CA	CANopen communication card	Supports CANopen bus communication
HVCOM-TP-H	EtherNet/IP communication card	Supports Modbus TCP/IP communication
HVCOM-EC-H	EtherCAT communication card	Supports EtherCAT communication
HVCOM-EN-H	EtherNet/IP communication card	Supports EtherNet/IP communication

Office Address: Building 11, Second Industrial Zone, Guanlong Village, Xili Street, Nanshan District, Shenzhen, P.R.China
Postal Code: 518055
Customer Service Hotline: 400-8828-705
Phone: +86-755-86026786
Website: www.hopewind.com

©2025 Hopewind Electric Co., Ltd.
All rights reserved. V4.1.3

