

HPPS Series 5MW



FEATURES

- 2 sets of 2.5MW central PCS integrated into a 20 feet container to reduce floor space
- Strong environmental adaptability with C4~C5 anti-corrosion degree available
- PCS liquid cooling, no derating up to 51°C
- Multiple operating modes supported such as PQ and VSG. Satisfy grid-forming functions
- Flexible capacity configuration and customizable MV voltage level of 6~35kV

TOPOLOGICAL GRAPH

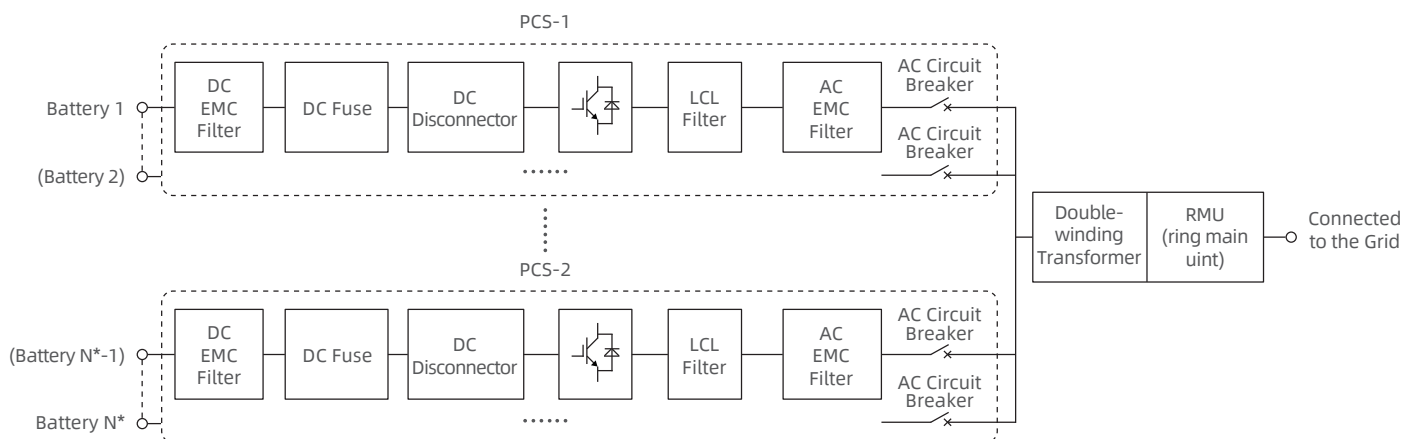

Note: N*=2 or 4

PARAMETERS

Model	HPPS-5000	HPPS-5000A
DC Parameters		
Number of DC Input Channels	4	2
Max. DC Current	1406A*4	2812A*2
DC Voltage Operating Range	1000~1500V	
AC Parameters		
Total Rated Power	5000kW	
Max. Output Power	5500kVA	
Rated Voltage	690Vac	
Isolation Mode	Transformer Isolation	
Reactive Power Range	0~5250kvar	
On-grid Mode		
Rated Grid Voltage	6~35kV (customizable)	
Rated Grid Frequency	50Hz / 60Hz	
THDi	<3%	
Power Factor	-1~1	
Transformer Parameters		
Rated Capacity	5250kVA	
Transformer Type	Oil-immersed Transformer	
LV/MV Voltage	0.69 / (6~35) kV	
System Parameters		
Dimensions (W*H*D)	6058*2896*2438mm	
Operating Temperature	-40~+60°C (PCS derating above 51°C, transformer derating is optional for 40°C to 51°C)	
Operating Humidity	4~100% (non-condensing)	
Operating Altitude	≤4000m (no derating within 3000m)	
Protection Degree	IP54 (PCS IP66)	
BMS Communication	RS485 / CAN	
EMS Communication	Ethernet	
Communication Protocol	Modbus TCP / IEC 61850 / IEC 104 / Modbus RTU / CAN 2.0	
Standard Compliance	PCS: IEC 61683, IEC 60068, IEC 62116, IEC TS 62910, etc. MV Transformer: IEC 60076 (Please contact Hopewind team for latest certifications)	
Grid Support	H/LVRT, frequency adjustment function, voltage adjustment function, inertia response, etc.	

*The table only lists some models. Products can be customized for projects.

*Please refer to the latest physical product for any changes in specifications.