



HOPEWIND

Stock Code: SSE-603063

Hydrogen Production Power Supply Product Manual

Shenzhen Hopewind Electric Co., Ltd. (Stock Code: 603063) focuses on the R&D, production, sales and service of renewable energy and electric drive products, with main products of wind power generation products, photovoltaic (PV) generation products, energy storage products, power quality products, and electric drive products, etc. Furthermore, Hopewind owns independent development and testing platforms of integrated high-power power electric equipment and monitoring system. Through innovation in technology and service, Hopewind continuously creates value for customers, and has become one of the most competitive enterprises in the renewable energy field nationwide.

In the field of electrolytic hydrogen production power supply, the IGBT rectification power supply scheme launched by Hopewind product can be adapted to electrolyzer below 1500V, support multi-machine parallel operation, which can meet requirements of electrolytic hydrogen production in multiple scenarios.

[Honors]



National Science and Technology Progress Award



Laboratory Qualification Approved by CNAS



National High-Tech Enterprise

[System Certifications]



ISO 9001:2015



ISO 14001:2015

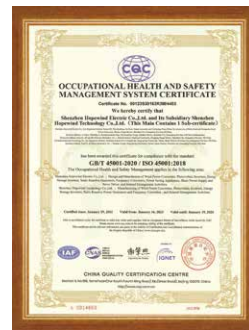

ISO 45001:2018

Headquarter · Shenzhen

5 R&D and manufacturing bases: Shenzhen, Suzhou, Xi'an, Heyuan, Wuhan

30+ global service bases: Deployed worldwide to provide comprehensive services for global customers



Overview

Hopewind HHP series electrolytic hydrogen production power supply products ("Hopewind hydrogen production power supply" for short) adopt a fully-controlled IGBT topology scheme and a modular redundant design, thus featuring high efficiency, high reliability, high power factor and low harmonics. Inheriting and drawing on the company's successful application of and experience in new energy power generation and large drive, Hopewind Hydrogen production power supply is characterized by optimized design, reliability and stability, easy maintenance and high adaptability.

Naming Rules

HHP - 6600 - 740 - A / I / N

Product name:
Hopewind Hydrogen Production Power Supply

Rated output current:
6600A

Rated output voltage:
740Vdc

Cooling method:
A: Air cooling, L: Liquid cooling

Place:
I: Indoor, O: Outdoor container

Altitude:
N: Normal, P: Plateau, U: Ultra Plateau

Typical Power Supply Cabinet



>> AC/DC Single-Stage Topology IGBT Power Supply

Performance & Features

- Suitable for 600~1500V electrolyzer
- Regulation with a wide power range of 10~110% and fast response
- High power factor of above 0.99 ($\geq 30\%P_n$) and reactive power support as needed
- Good grid-involved characteristics, with grid harmonic current THDi $\leq 3\%$, and SCR ≤ 1.5
- High efficiency in full power range, efficiency exceeds 97% (above 30% P_n), maximum efficiency 98.5%
- Good parallel characteristics and easy system expansion
- Supporting air cooling/liquid cooling and easy maintenance



Product Working Principle

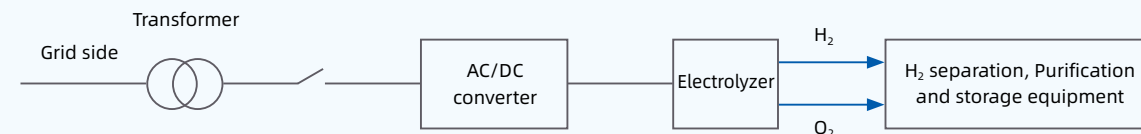

Technical Parameters

Product		AC/DC Single-Stage Topology Series
DC Parameters	Output Voltage Range	600V~1500V
	Output Current Range	Meeting customized needs
	DC Voltage Ripple	$\leq 1\%$
	DC Stabilized Current Precision	$\pm 0.5\%$ (steady state)
	DC Stabilized Voltage Precision	$\pm 0.5\%$ (steady state)
	Load Response Time	$< 0.1s$ (0%~100% load, running state)
	Output Control Mode	Current control (default), Voltage control, Power control
AC Parameters	Input AC Voltage Range	380V~900V
	Rated Operating Frequency	50Hz / 60Hz
	Rated Power Factor	> 0.99 (over 30% P_n)
	Adjustable Power Factor Range	-0.95 Lead~0.95 Lag
	Allowable Grid Frequency Deviation	$\pm 10\%$
	Allowable Grid Voltage Deviation	$\pm 10\%$
	Total Harmonic Distortion Rate of Grid-connected Current	$< 3\%$ (over 30% P_n)
	Access Method	3-phase 3-wire+PE
System	Wiring In / Out Mode	Meeting customized needs
	Efficiency	Maximum efficiency 98.5%
Environmental Requirements	Cooling Method	Temperature-controlled air cooling / Liquid cooling
	Working Temperature Range	$-40^{\circ}C \sim +55^{\circ}C$
	Electromagnetic Environment Category	Class A
	Relative Humidity	0%~95% (no condensation)
	Enclosure Protection Rating	IP23 / IP54
External Communication	Highest Altitude of Installation Site	4000m
	External Communication Interface	RS485, Ethernet and 4mA~20mA digital analog, etc.
	External Communication Protocol	Modbus RTU, Modbus TCP
Display	HMI	Touch screen (optional)

>> AC/DC+DC/DC Two-Stage Topology IGBT Power Supply

Performance & Features

- Suitable for 0~900V electrolyzer
- Regulation with a wide power range of 10~110% and fast response
- High power factor of above 0.99 ($\geq 30\%P_n$) and reactive power support as needed
- Good grid-involved characteristics, with grid harmonic current THDi $\leq 3\%$, and SCR ≤ 1.5
- High efficiency in full power range, efficiency exceeds 96% (above 30% P_n), maximum efficiency 97.5%
- Good parallel characteristics and easy system expansion
- Supporting air cooling/liquid cooling and easy maintenance



Product Working Principle

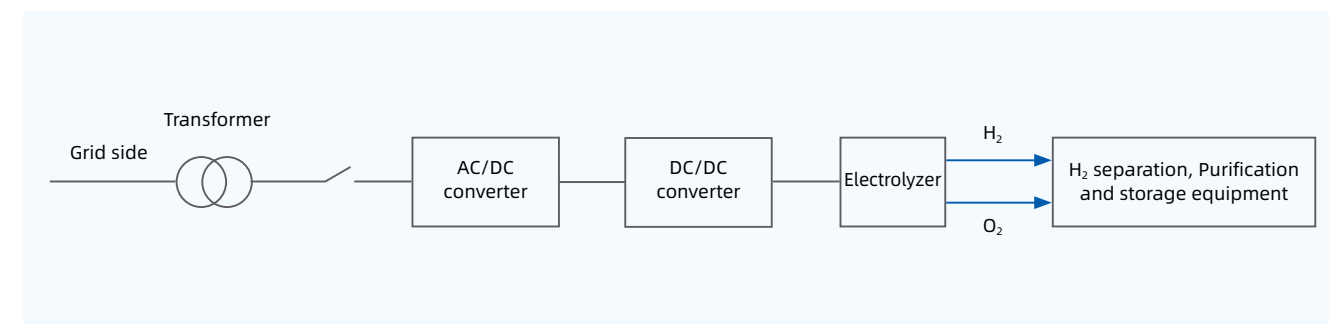

Technical Parameters

Product		AC/DC+DC/DC Two-stage Topology Series
DC Parameters	Output Voltage Range	0V~900V
	Output Current Range	Meeting customized needs
	DC Voltage Ripple	$\leq 1\%$
	DC Stabilized Current Precision	$\pm 0.5\%$ (steady state)
	DC Stabilized Voltage Precision	$\pm 0.5\%$ (steady state)
	Load Response Time	$< 0.1s$ (0%~100% load, running state)
	Output Control Mode	Current control (default), Voltage control, Power control
AC Parameters	Input AC Voltage Range	380V~690V
	Rated Operating Frequency	50Hz / 60Hz
	Rated Power Factor	> 0.99 (over 30% P_n)
	Adjustable Power Factor Range	-0.95 Lead~0.95 Lag
	Allowable Grid Frequency Deviation	$\pm 10\%$
	Allowable Grid Voltage Deviation	$\pm 10\%$
	Total Harmonic Distortion Rate of Grid-connected Current	$< 3\%$ (over 30% P_n)
	Access Method	3-phase 3-wire+PE
System	Wiring in / Out mode	Meeting customized needs
	Efficiency	Maximum efficiency 97.5%
Environmental Requirements	Cooling Method	Temperature-controlled air cooling / Liquid cooling
	Working Temperature Range	$-40^{\circ}C \sim +55^{\circ}C$
	Electromagnetic Environment Category	Class A
	Relative Humidity	0%~95% (no condensation)
	Enclosure Protection Rating	IP23 / IP54
Highest Altitude of Installation Site	4000m	
External Communication	External Communication Interface	RS485, Ethernet and 4mA~20mA digital analog, etc.
	External Communication Protocol	Modbus RTU, Modbus TCP
Display	HMI	Touch screen (optional)

Renewable Energy-Based Hydrogen Production Panoramic Monitoring Solution

- Supporting local and cloud-based deployment monitoring
- Massive data acquisition, storage, statistics, computing and analysis enabled by the monitoring server
- High compatibility: Supporting Windows, Linux and domestically developed operating systems with high security and reliability
- User-friendly interface: Dynamic component display under multiple standards
- Ease of deployment, flexible and convenient configuration, and intuitive monitoring interface
- Supporting operation across platforms such as servers, industrial control screens and PCs

Hopewind EMS

- As the control center of green power-based hydrogen production, EMS can coordinate multiple devices for safe and stable operation
- EMS can generate the optimal power curve of hydrogen production based on wind/PV power generation forecasts and energy storage system status and make proper corrections according to system inputs
- Working with energy storage, EMS can make full use of new energy power generation for maximum hydrogen production efficiency and be adapted to off-grid and grid-connected scenarios
- EMS supports coordinated control among multiple electrolyzers mainly under the "capacity assessment + shift control" strategy, thus shortening the start-up time and averaging the production cycle for electrolyzers
- The station layer-EMS control layer-controlled equipment layer networking architecture can enable layered control for higher control efficiency and reliability
- EMS supports grid-connected and off-grid scenarios, fully adapting to renewable energy-based hydrogen production

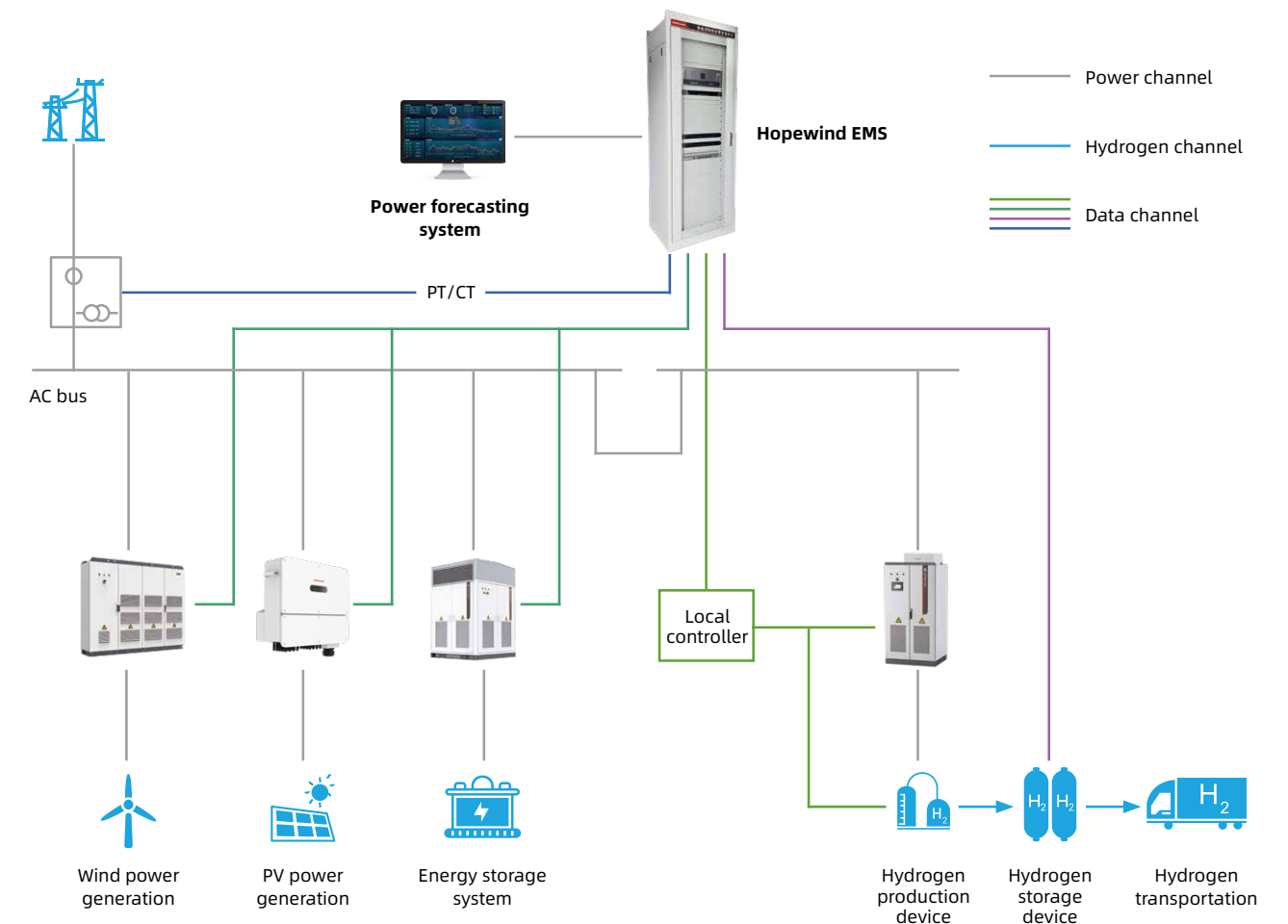
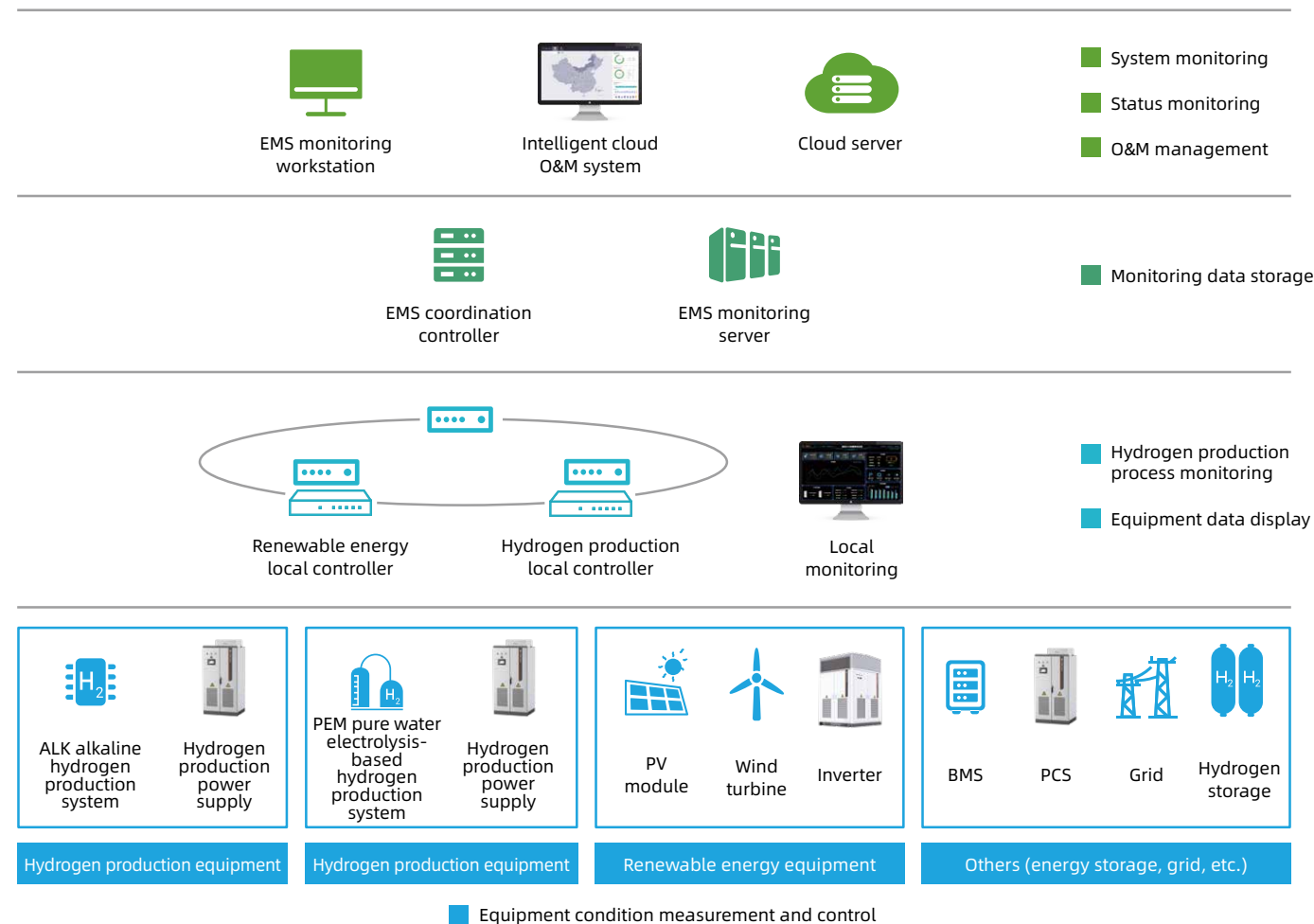

Performance & Features

- Stable operation: High-performance chips, real-time operating systems, and highly stable hardware and software
- High efficiency and reliability: Modular design featuring customization, power distribution optimization, high control accuracy and supporting fault locating, recording and history inquiry
- Active-standby configuration: Supporting configuration of both active and standby controllers for automatic switchover, greatly improving system stability
- Multi-scenario application: Applicable to grid-connected/off-grid energy management scenarios covering hydrogen production, power grid, wind power, PV power, and energy storage
- Strategy customization: Supporting both conventional control modes and customized development



System Specifications

Panel Cabinet Input Power	220Vac / 50Hz
Control Unit Input Power	24Vdc, Max.4A
Device Communication Interface	RJ45, RS485, DO, AO
Operating System	Linux, Windows
Monitoring Display	Workstation
Working Temperature	-40°C~+65°C
Storage Temperature	<90°C
Relative Humidity	20%~90%
Dimensions (H*W*D)	2260*800*600 / 2260*800*800 (mm)

▶ Application in Shaanxi

Hopewind hydrogen production power supply HHP-4500-200 was applied by a chemical manufacturer in Shaanxi. This project is a power supply system with two channels of power, namely, AC power grid and PV power. The hydrogen production power supply has different operating modes:

(1) Grid power-based mode; (2) Off-grid PV power-based mode; (3) PV + grid power-based mode.

This project requires complex system functions. Hopewind's IGBT hydrogen production power supply solution can well adapt to the volatility in renewable energy power generation. The system has the MPPT function that can track the maximum power of the PV system in real-time, apart from working well under different working modes. It is a significant breakthrough in operating modes of renewable energy-based hydrogen production.

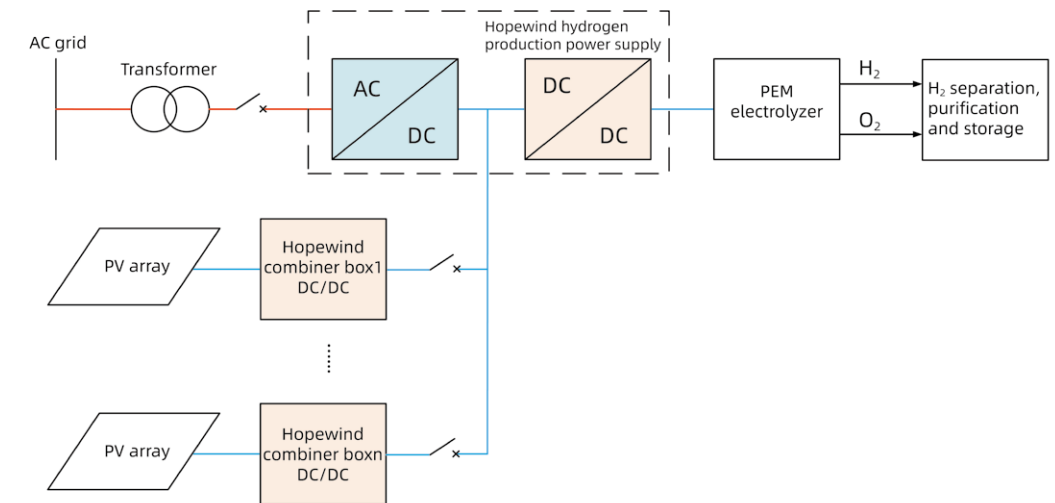

▶ Application in Yunnan

Hopewind hydrogen production power supply HHP-16000-170 matched with a Low-Voltage and High-Current (170V/16000A) hydrogen production electrolyzer was applied by a PV module manufacturer in Yunnan.

The product parameters are designed as per the altitude of 3000 meters, and the equipment operates stably. The lthd, Uthd and power factor of the IGBT hydrogen production power supply significantly outperform those of the thyristor hydrogen production power supply, as demonstrated by lower system harmonic loss and better grid adaptability.

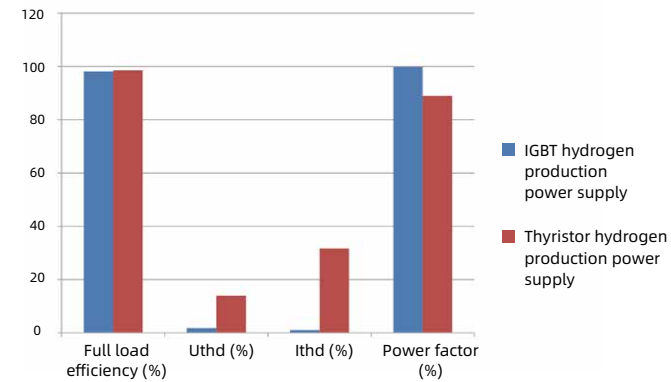

Test comparison between thyristor hydrogen production power supply scheme and that of the IGBT

▶ Application in Gansu

Hopewind hydrogen production power supply HHP-12900-546 matched with two sets of ALK electrolyzer was applied in a hydrogen production demonstration base in Gansu. Hopewind IGBT hydrogen power supply power density is high, small footprint, strong environmental adaptability, a one-off operation in low temperature conditions, to help the customer first hydrogen production project smoothly!

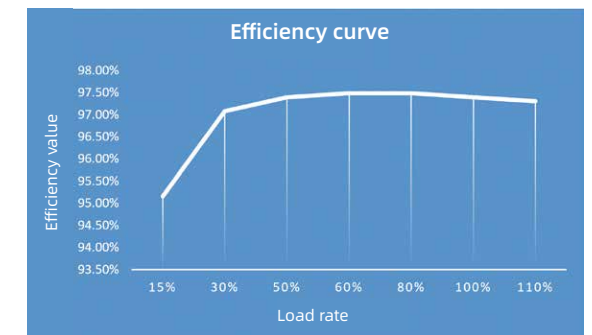

► A Project in Australia

A Project in Australia, Hopewind provided water-cooled IGBT Power Supply For Hydrogen Production with the model as HHP-10450-546. Hopewind IGBT Power Supply For Hydrogen Production has obtained CE certification from authoritative organization with safety regulation and EMC certificates. Meanwhile, the power supply for hydrogen production for project is designed in strict accordance with Australian standards and IEC related standards, which meets the local requirements of Australia.

In the project, basing on renewable energy and to electrolysis into hydrogen, its produced hydrogen will be used for blending with natural gas, which reduces carbon emissions from the industrial production process and people's daily lives, helping the region to achieve net-zero emissions at an early date.



► A Project in Jiangsu, China

In a demonstrative project in Jiangsu, China for hydrogen production with photovoltaic energy, Hopewind provided the entire hopeEMS, the management system for renewable energy to produce hydrogen, which supports multi-source energy dispatching and multi-device coordinated control. The system features control strategies customized based on the control characteristics and boundary constraints of the hydrogen production equipment. It enables efficient use of renewable energy, ensures the safety and reliability of the hydrogen production system, and maximizes hydrogen production efficiency. It also allows for visual monitoring of the hydrogen production system.

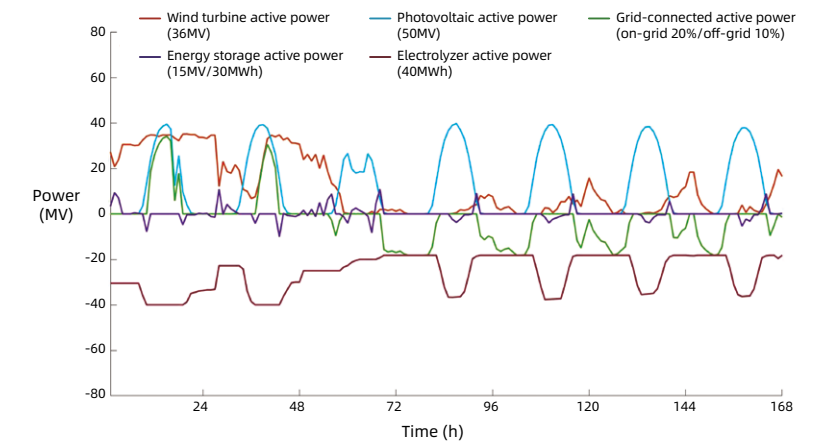

Active power dispatching curve of grid-connected power plant

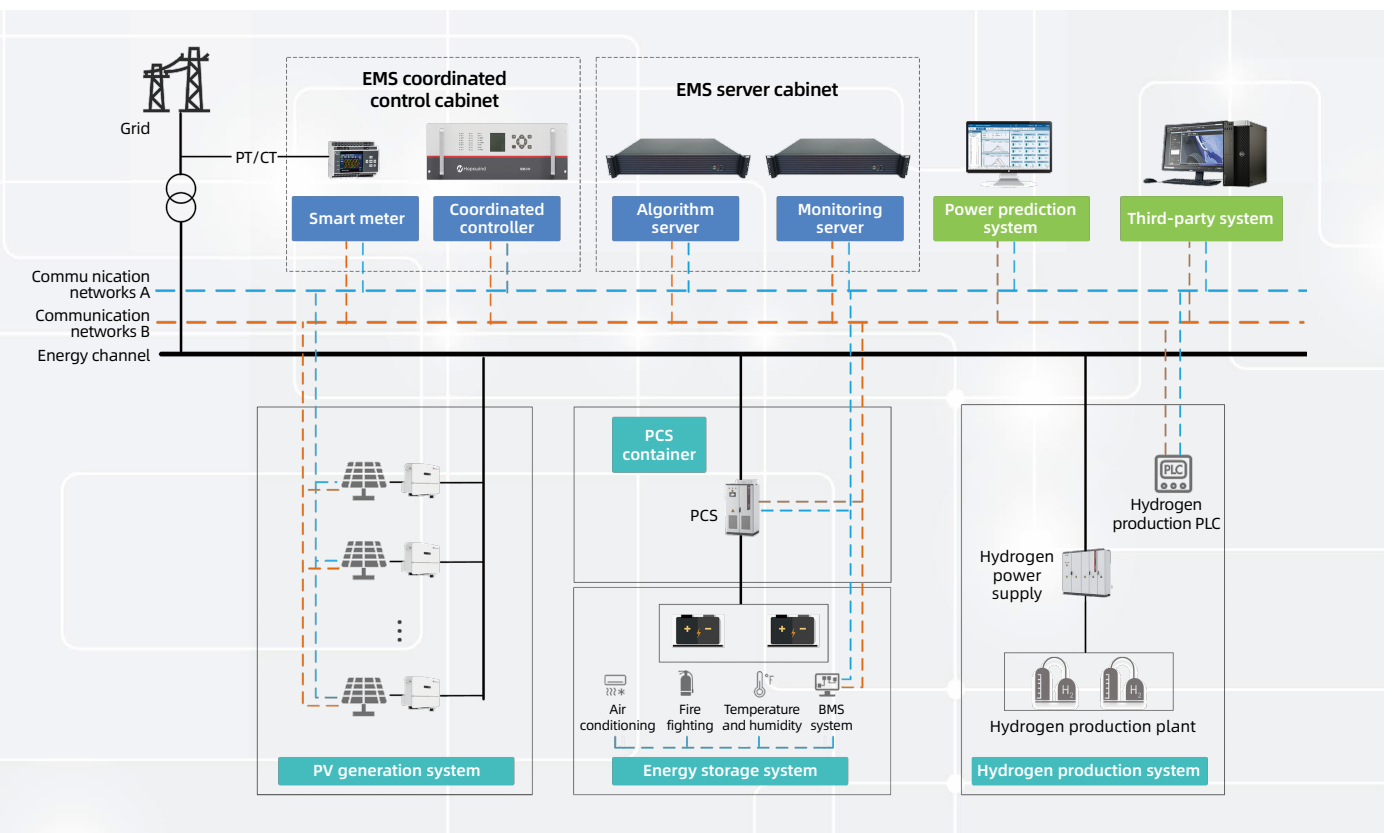

150 GW⁺

SHIPMENTS WORLDWIDE



Email: marketing@hopewind.com

Tel: +86 189 4874 2347

Website: www.hopewind.com

©2025 Hopewind Electric Co., Ltd. All rights reserved. V4.0.6

If the product size and parameters have changed, the latest actual product shall prevail.