

HOPEWIND

GREEN UTILITY SOLUTION

The highest power string inverter among industry

HSHV320/330/ 350/385K -G02

TIER 1
BloombergNEF

Hopewind is ranked as
Tier 1 Solar Inverter Maker by BNEF



FEATURES



Higher Performance

- 65A MPPT current, compatible with all types modules
- Full power operation at high temperature of 45°C (385K@40°C)
- Advanced SIC design, better efficiency & life time



More Reliable

- IP66 & optional C5 anti-corrosive for harsh environment
- Low SCR, compatible with weak grid situations
- AFCI, DC&AC temperature protection with smart DC switch
- Explosion relief valve for on-site personal safety



Lower Cost

- Compatible with Aluminium cable of AC-side
- PLC communication to reduce wiring costs
- Anti-PID & Night SVG



Convenient O&M

- Integrated with Aux. switch, initial debugging at any time
- 24/7 continuously monitoring
- Fault waveform recording on hopeCloud
- Smart IV curve diagnosis

TOPOLOGICAL GRAPH

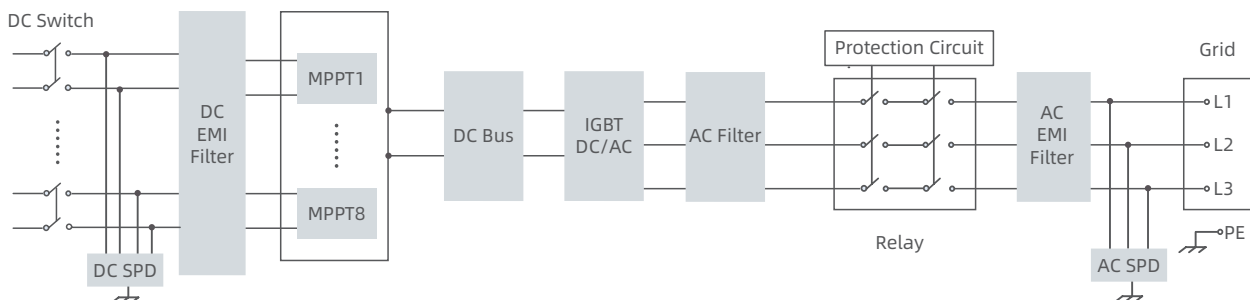

PARAMETERS

Model	HSHV320K-G02	HSHV330K-G02	HSHV350K-G02	HSHV385K-G02
DC Input				
Max. Input Voltage	1500 V			
Starting Voltage	550 V			
MPPT Voltage Range	500~1500 V			
MPPT Range Full Load	960~1300 V			
Max. Input Current Per MPPT	65 A			
Max. Short-circuit Current	97.5 A			
Number of DC Inputs	8 × 4			
Number of MPP Trackers	8			
AC Output				
Rated Output Power	320 kW	330 kW	350 kW	385 kW
Max. Output Power	320 kW	330 kW	350 kW	385 kW
Rated Output Voltage	800 V (3P + PE)			
Operating Voltage Range	640~920 V			
Rated Output Current	230.9 A	238.2 A	252.6 A	277.9 A
Max. Output Current	230.9 A	238.2 A	252.6 A	277.9 A
Rated Grid Frequency	50 Hz / 60 Hz			
Power Factor	>0.99 (0.8 leading~0.8 lagging)			
Harmonic (THD)	<3% (at rated power)			
Efficiency				
Max. Efficiency	99.01%			
European Efficiency	98.70%			
Protection				
Surge Protection	DC type II / AC type II			
Insulation Impedance Detection	Yes			
Residual Leakage Current Detection	Yes			
PV String Fault Detection	Yes			
PV Reverse Polarity Protection	Yes			
Anti-Islanding Protection	Yes			
Output Overcurrent Protection	Yes			
DC Switch	Yes			
AFCI	Optional			
Smart IV Curve Diagnosis	Optional			
PID Recovery	Yes			
Night SVG Function	Optional			
General Parameters				
Dimensions (W × H × D)	1208 × 967 × 396 mm			
Weight	155 kg			
Protection Degree	IP66			
Operating Temperature Range	-30~+60°C ^①			
Cooling System	Smart air cooling			
Standby Power Consumption	<24 W			
Topology	Transformerless			
Operating Altitude	4000 m (>3000 m derating)		4000 m (>2000 m derating)	
Display	LED indicator, Wi-Fi / APP			
Communication	RS485 / PLC			
DC Connection Type	MC4			
AC Connection Type	OT / DT terminal (≤400 mm ²)			

① Able to start at -40°C.

Note: The contents of the previous version are parameters for planned development and do not constitute a commitment to product performance.